

Problem 1 – Generator Shuts Down for Under Voltage (Continued)

NOTE: Evolution 1.0 (non-Synergy) Firmware (v1.12 and above) and Evolution 2.0 (all firmware), perform the Preliminary Output Voltage Test.

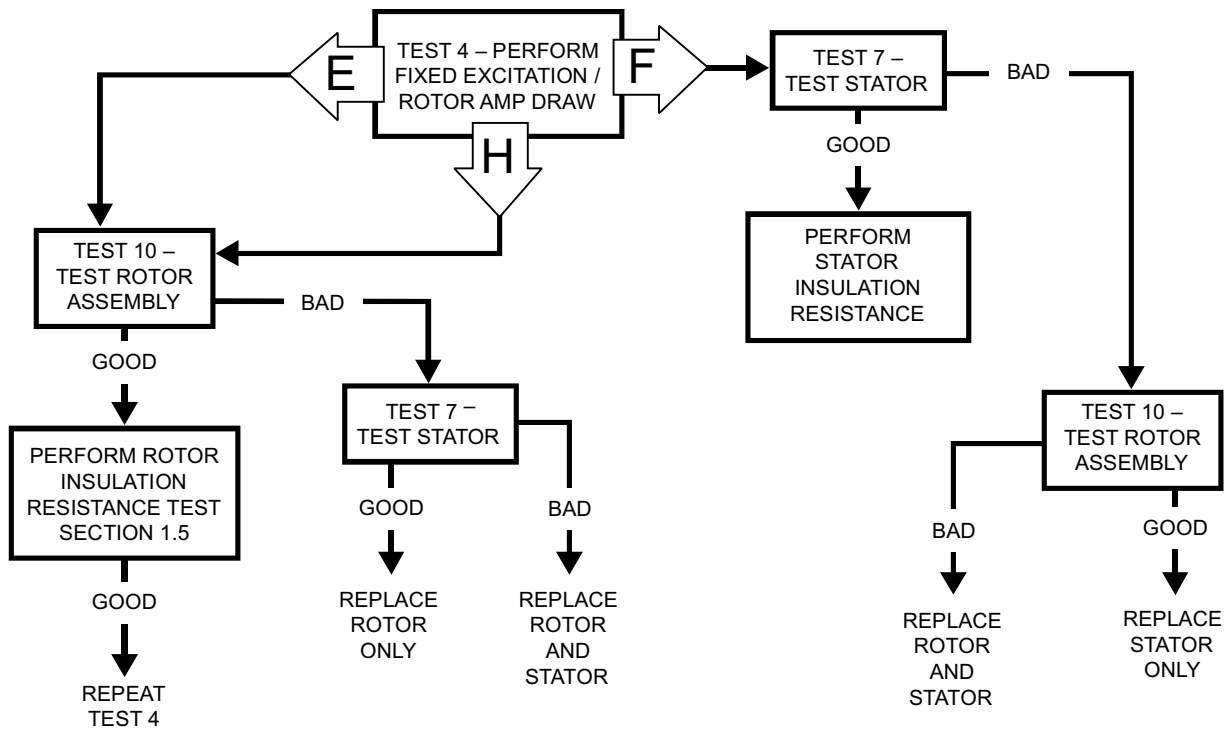

003108

Problem 2 – Generator Produces High Voltage

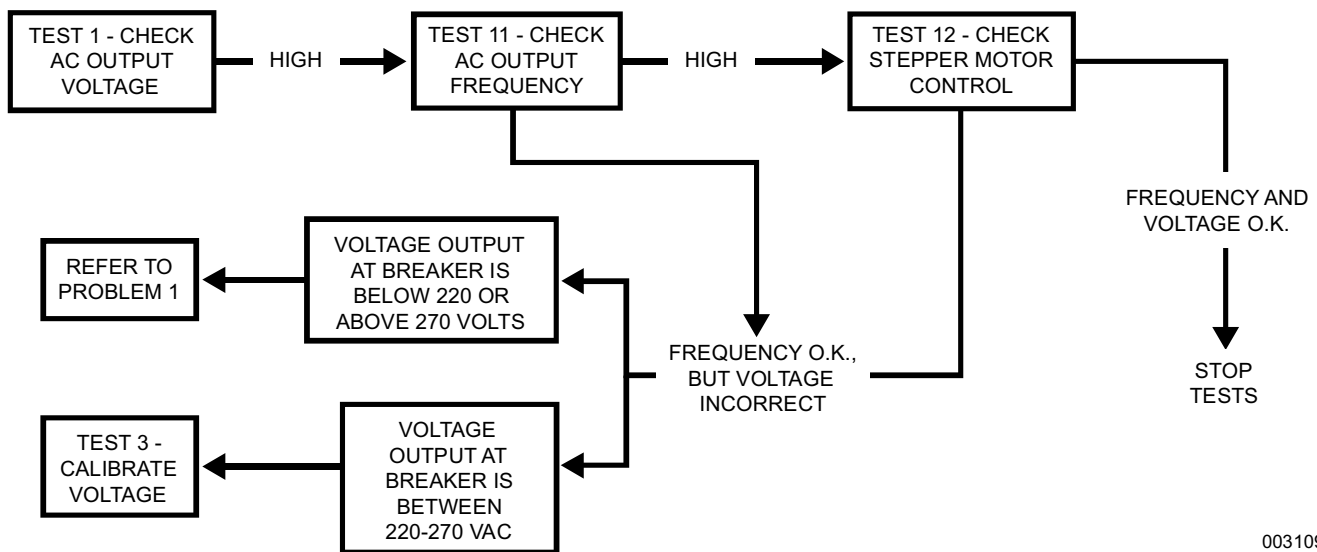

003109

IMPORTANT NOTE: Clear any faults in the controller before proceeding with any running diagnostic steps!